

Oily Water Separator DVZ - FSU "OILCHIEF"®

- Type approved according to IMO RESOLUTION MEPC 107 (49)
- Optional with type approved FSU© by-pass function
- Capacity from 150 l/h up to 10.000 l/h
- Jet-wash oil drainage
- Available in stainless steel and shock approved
- Compact design
- Easy installation
- Pump can optionally be used as separate transfer pump



Oily Water Separator:

DVZ - FSU "OILCHIEF"®



System Description

The newly developed oily water separator DVZ-FSU-"OILCHIEF" is a fine separation unit constructed as the sum of details and more than 25 years experience in plant design and development that implements highest standard in plant quality. An intelligent interplay of coalescence and fine separation realizes an oil content of less than 15 ppm according to IMO Resolution MEPC 107 (49) in treated water. This limit value is continuously monitored and recorded by an oil-in-water monitor installed on the separator. The well-known features like JET-WASH oil drainage and self-cleaning coalescer are just as much standard features of the DVZ-FSU-"OILCHIEF" as are automatic mode and low maintenance cost.



The flexible plant concept of the DVZ-FSU-"OIL-CHIEF" allows the pump to be used separately, e.g. in the case of high suction height or as transfer pump. The new types of fine separation filter cartridges developed in our laboratory distinguish themselves by a high service life and a high operational reliability. The special surface of the filter cartridges enhances the coalescence characteristic of the dispersed oil and allows a rising in the oil collection dome for subsequent automatic drainage. The inseparable components in the bilge water are retained in the innovatively designed fine separation filter cartridge and allow a treatment of emulsions in accordance with IMO Test Specification. The service life of the cartridge is obviously determined by the level of the contamination and the input concentration of the bilge water. According to the physical term of 'mass balance', the service life is determined by the ratio of untreated water quality to treated water quality.

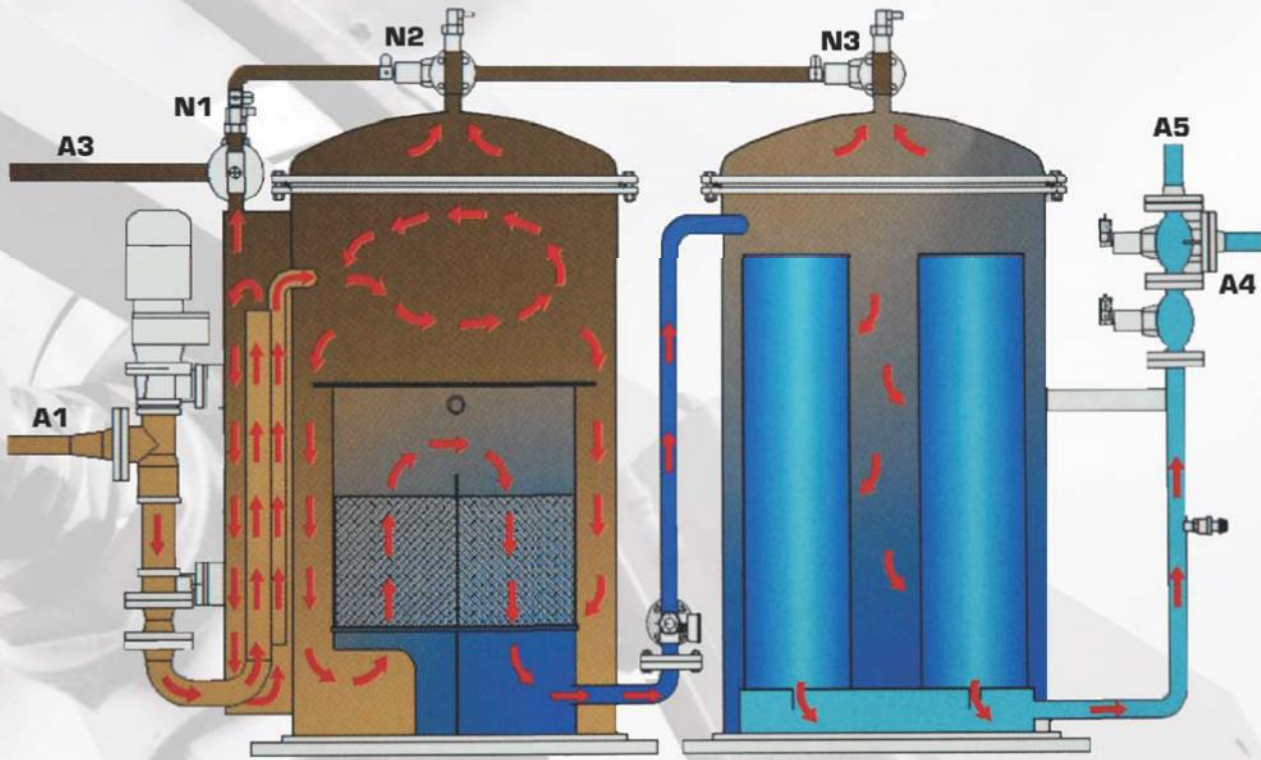

Functional Description

In the newly developed separator generation of the DVZ-FSU- "OILCHIEF" series, the separation process is effected in three stages. The delivery pump P1 sucks the untreated water direct from the bilge or the bilge tank and delivers it to the coarse separation stage 1. This is where the free oil is physically separated from the water and automatically fed into the oil collection tank. The remaining liquid is then delivered to the main separation stage and set in rotation by a hydrocyclone. This centrifuge effect has a positive effect on the separation process. The lighter oil phase accumulates in the centre of the separator and rises up to the oil collection chamber while the heavier water phase moves outwards and then downwards.

When a defined oil quantity has accumulated in the oil collection chamber, it is automatically discharged to the waste oil tank. During the process stage 2, the oil-water phase is diverted by 180° and routed vertically from the bottom to the top, in a physically logical way, through a so-called coalesces, where tiniest oil drops combine here and then rise by gravity up to the oil collection chamber for separation. Solids, which may reach the separator with the oil-water phase, settle in the **bottom area of the separator and can be drained off as required.**

The special lay- out of the coalesces stage and the special geometry of the coalescence inserts ensure that a blockage caused by dirt particles is almost impossible and thus allow a long service life and thus a reduction of operating and maintenance costs. In the downstream fine separation stage (DVZ-FSU), respectively process stage 3, emulsified oil is separated from the water phase.

The core components of process stage 3 are the newly developed, scientifically designed and tested fine separation filter cartridges (DVZ-FSC). They allow the treatment of oilwater mixtures in accordance with IMO resolution MEPC 107 (49) with a residual oil content of less than 15 ppm.

The special feed flow direction and the special do-sign of the fine separation filter cartridges allows a high separation level and thus a long service life. Available as an option is a type-tested fine separation bypass function, which automatically bypasses the fine separation stage when the oil content is less than a preset level and thus reduces the cost and increases the operational reliability. After process stage 3, the treated water is continuously monitored by an oil-in-water monitor and automatically routed, by a 3-way valve, overboard or back to the bilge if the oil limit value is exceeded.

Main dimensions of the standard series

(special design on request)

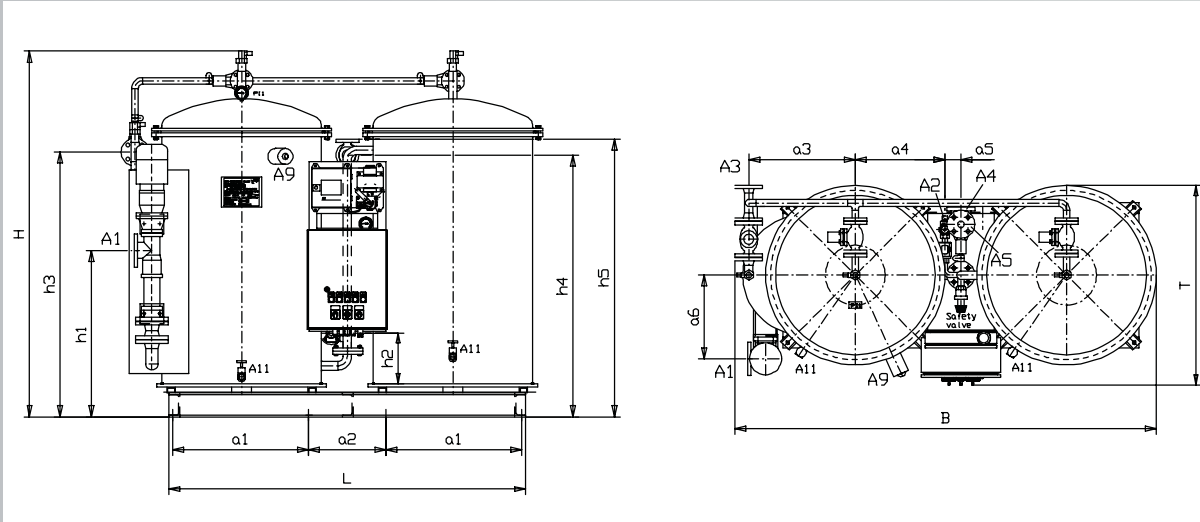

TYPE	FSU 250	FSU 500	FSU 1000	FSU 2500	FSU 5000	FSU 10000
Capacity [l/h]	250 l/h	500 l/h	1000 l/h	2500 l/h	5000 l/h	10000 l/h
B [mm]	960	1155	1155	1620	2120	3050
H [mm]	1200	1250	1350	1640	1840	1920
T [mm]	765	835	835	890	1060	1350
L [mm]	820	960	960	1310	1790	2550
a1 [mm]	275	335	335	470	680	990
a2 [mm]	230	250	250	350	380	520
a3 [mm]	210	260	260	388	535	765
a4 [mm]	252	290	290	410	530	755
a5 [mm]	125	155	155	90	110	185
h1 [mm]	560	650	650	655	840	980
h2 [mm]	240	250	250	255	255	275
h3 [mm]	775	880	980	1260	1460	1450
h4 [mm]	975	975	1075	1295	1320	1290
h5 [mm]	1010	1010	1110	1375	1410	1390
d [mm]	d 324	d 406	d 406	d 600	d 800	d 1250
A1	DN 25	DN 25	DN 25	DN 50	DN 50	DN 80
A2	R 3/4"	R 3/4"	R 3/4"	R 3/4"	R 3/4"	R 3/4"
A3,A4,A5	R 3/4"	R 3/4"	R 3/4"	DN 25	DN 25	DN 40
Empty weight kg	360	460	480	1700	2500	5460
Operation weight kg	490	684	728	1700	2500	5460

Subject to technical modifications without notice.

DVZ-SERVICES GmbH

Boschstrasse 9 D-28857 Syke

Phone: +49 (0)4242 - 16938 - 0

Fax: +49 (0)4242 - 16938 - 99

E-Mail: info@dvz-services.de

www.dvz-services.de

DVZ-GROUP



Approved by:

